

# OPERATION MANUAL

## FW – SERIES FLOW MONITOR

### MODEL: F012-P

## RATE / TOTALIZER

Signal input: coil, pulse, Namur

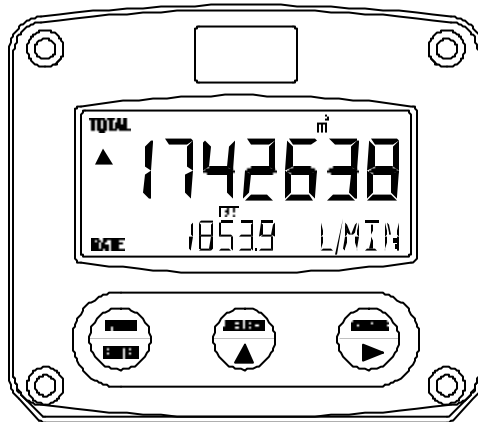

Hardware version : V02.01.03  
Software version : 01.01.xx  
Manual : H\_F012PEN\_v010108.doc

Information in this manual might change without prior notice. The manufacturer is not responsible for mistakes in this material or for incidental damage direct or indirect as a result of this delivery, performance or use of this material.

All rights reserved. No parts of this publication may be reproduced or used in any form or by any means without written permission of your supplier.

Warning: Any responsibility is lapsed if the instructions and procedures as described in this manual are not followed.

**LIFE SUPPORT APPLICATIONS:** The products F012-P-series are not designed for use in life support appliances, devices, or systems where malfunction of the product can reasonably be expected to result in a personal injury. Customers using or selling these products for use in such applications do so at their own risk and agree to fully indemnify the manufacturer and supplier for any damages resulting from such improper use or sale.

- ◆ **WARNING!!** Electro static discharge does inflict irreparable damage to electronics! Before installing or opening the unit, the installer has to discharge himself by touching a well-grounded object.
- ◆ **WARNING!!** This unit must be installed in accordance with the EMC guidelines (Electro Magnetic Compatibility).

**SAFETY RULES AND PRECAUTIONARY MEASURES**

- The manufacturer accepts no responsibility whatsoever if the instructions and procedures as described in this manual are not followed.
- Modifications of the F012-P implemented without prior written consent from the manufacturer, will result in the immediate termination of product liability and warranty period.
- The manufacturer accepts no responsibility whatsoever if the following safety rules and precautions are not observed.
- Installation, use, maintenance and de-mounting of this equipment must be carried out by authorized technicians.
- Check the mains voltage and information on the manufacturer's plate before installing the unit.
- Check all connections, settings and technical specifications of the various peripheral devices and the rate/totaliser F012-P.
- Open the casing only if all leads are potential free.
- Never touch the electronic components (ESD sensitivity).
- Never expose the system to heavier conditions than allowed according to the casing classification (see manufacture's plate and chapter 4.2.).
- If the operator detects errors or dangers, or disagrees with the safety precautions taken, then inform the owner or principal responsible.
- The local labor and safety laws and regulations must be adhered to.

**CONTENTS:**

Safety rules and precautionary measures .....	2
Contents: .....	2
1. Introduction .....	3
1.1. About the operation manual .....	3
1.2. Control panel .....	3
1.3. Brief description of the rate/Totalizer F012-P .....	3
2. Operational .....	4
2.1. General .....	4
3. Configuration .....	5
3.1. Introduction .....	5
3.2. Programming SETUP-level .....	5
3.2.1. General .....	5
3.2.2. Prog-procedure .....	7
3.2.3. SETUP .....	7
3.2.3.1. Total - 1 .....	7
3.2.3.2. Flowrate - 2 .....	8
3.2.3.3. Display - 3 .....	8
3.2.3.4. Power management - 4 .....	9
3.2.3.5. Flowmeter - 5 .....	9
3.2.3.6. Others - 6 .....	10
4. Installation .....	11
4.1. General directions .....	11
4.2. Installation / surrounding conditions .....	11
4.3. Dimensions .....	11
4.4. Installing the hardware .....	12
4.4.1. Introduction .....	12
4.4.2. Voltage supply flowmeter pick-up .....	12
4.4.3. Terminal connectors .....	13
5. Intrinsic safety connections .....	16
6. Maintenance .....	22
6.1. General directions .....	22
Appendix A: Technical specification F012-P .....	23
Appendix B: Problem solving .....	24
Index: .....	25
Notes: .....	26
List of actual settings F012-P .....	28

## 1. INTRODUCTION

### 1.1. ABOUT THE OPERATION MANUAL

This operation manual is divided into two main sections;

The daily use of the unit is described in chapter 2 "Operation". This instruction is meant for users. The following chapters and appendices are exclusively meant for electricians/technicians. These provide an extensive description of all software settings and installing the hardware.

### 11 SETUP-REFERENCES

In the margin of this manual, SETUP-references have been included so that explanations regarding SETUP-level can easily be looked up; 11 in this case, for example.

### 1.2. CONTROL PANEL

Following keys are available:



Fig. 1: Control Panel.

Functions of the keys:

- ◆ **PROG / ENTER**: This key has no function at operator level.  
It is used only to configure the unit; please read chapter 3.
- ◆ **SELECT / ^**: This key is used to SELECT accumulated total.  
The arrow-key ^ is only used to configure the unit; please read chapter 3.
- ◆ **CLEAR / >**: Press this key twice to CLEAR the actual value for Total.  
The arrow-key > is only used to configure the unit; please read chapter 3.

### 1.3. BRIEF DESCRIPTION OF THE RATE/TOTAL IZER F012-P

The rate/totaliser F012-P is a system driven by microprocessors for the displaying of flow rate, Total and accumulated Total. For that purpose, one flow meter with pulse or coil output can be connected to the F012-P.

The F012-P is designed to be implemented in many types of applications. For that reason, a SETUP-level is available to configure your rate/totaliser best according to your requirements. SETUP includes several important features as K-factors and measurement units.

Normally, the unit has to be powered with 8-30V DC. Optional available is battery powered. To extend the battery-life time, please make use of the power-management functions as described in chapter 3.2.3.3.

With the intrinsically safe option, Model F012-P-XI can be installed in hazardous area according to EEx ia IIB/IIC T4. Please read chapter 5 for more information.



## 2. OPERATIONAL

### 2.1. GENERAL

This chapter describes the daily use of the rate/totaliser. This instruction is meant for the users / operators.

In general, the rate/totaliser will always act at Operator level. The information displayed is depending on the SETUP-settings. Although the refresh-rate of the display might be slow (due to power-management functions), each flow meter pulse will be measured. After pressing a key, the display will be updated very fast during 30 seconds after which it will slow-down again.



Fig. 2: Example display information during process.

For the Operator, following functions are available:

- ◆ Display rate/Total or rate:  
This is the main display information of the F012-P. After selecting other information, it will return to the main display automatically. The actual flow rate is either displayed at the bottom line or with the 17mm digits at the upper line. When "-----" is shown, the flow rate value is too high to be displayed. The arrows ⇄ indicate the increase/decrease of the flow rate.
- ◆ Clear Total:  
The value for Total can be initialized. To do so, press CLEAR twice. After pressing CLEAR once, the text "PUSH CLEAR" is displayed while the display information is flashing. To avoid initialization in that stage, press a different key or wait for 20 seconds. Initialization of Total DOES NOT influence accumulated Total.
- ◆ Display accumulated Total:  
When the SELECT-key is pressed, Total and Accumulated Total are displayed. Accumulated Total can never be initialized. The value will count up to 99,999,999,999. The unit and number of decimals are according to Total.
- ◆ Low-battery alarm:  
When the battery voltage drops, it must be replaced. First "low-battery" will flash, but as soon as it is displayed continuously, the battery MUST be replaced soon! Only official batteries may be used, else the guarantee will be terminated. The remaining life time after the first moment of indication is in general several days up to some weeks.

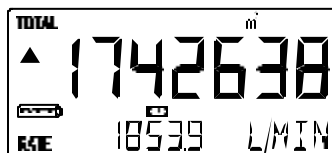

Fig. 3: Example of low-battery alarm.

- ◆ Alarm 01-04:  
When "alarm" is displayed, please consult Appendix B: problem solving.

### 3. CONFIGURATION

#### 3.1. INTRODUCTION

This and following chapters are exclusively meant for electricians and non-operators. In these, an extensive description of all software settings and hardware connections are provided.

- ◆ *Authorized technicians must carry out installation, use, maintenance and de-mounting of this equipment only.*
- ◆ *Take good notice of the "Safety rules and precautionary measures" in the front of this manual.*

#### 3.2. PROGRAMMING SETUP-LEVEL

##### 3.2.1. GENERAL

Configuration of the F012-P is done at SETUP-level. SETUP-level can be reached by pressing the PROG/ENTER key for 7 seconds; in the meantime both arrows  $\blacktriangleleft$   $\blacktriangleright$  are displayed. In order to return to the operator level, PROG will have to be pressed for three seconds. Also, when no keys are pressed for 2 minutes, SETUP will be left automatically.

SETUP can be reached at all times while the F012-P remains full operational.

##### Password:

A password may be required to enter SETUP. Without this password access to SETUP is denied.

SETUP is divided into several main- and sub-functions. Main functions are selected with  $\blacktriangleright$  and sub-functions with  $\blacktriangleup$ .

Each function has a unique number, which is displayed below the word "SETUP" at the bottom of the display. The number is a combination of two figures. The first figure indicates the main-function and the second figure the sub-function: 12 is the second sub-function of main-function 1. Furthermore, each function is expressed with a keyword.

After selecting a sub-function, the next main function can first be selected after scrolling through all "active" sub-functions (like 1 $\blacktriangleup$ , 11 $\blacktriangleup$ , 12 $\blacktriangleup$ , 13 $\blacktriangleup$ , 14 $\blacktriangleup$ , 1 $\blacktriangleright$ , 2 $\blacktriangleright$ , 3 $\blacktriangleright$ , 31 etc.).

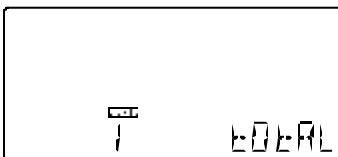

Fig. 4: Example of main-function 1.

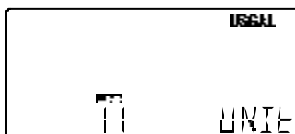

Fig. 5: Example of sub-function 11: unit for Total.

SETUP has been divided as follows:

↓			
↓		←	14 DECIMALS K-FACTOR: 0 - 6
		←	13 K-FACTOR: 0.000010 - 9,999,999
		←	12 DECIMALS: 0 - 1 - 2 - 3
1	TOTAL	←	11 UNIT: L - m3 - kg - lb - GAL - USGAL - bbl - no unit
↓			
↓		←	27 CUT-OFF: 0.1 - 999.9 seconds
		←	26 CALCULATION: per 1 - 255 pulses
		←	25 DECIMALS K-FACTOR: 0 - 6
		←	24 K-FACTOR: 0.000010 - 9,999,999
		←	23 DECIMALS: 0 - 1
		←	22 TIME UNIT: sec - min - hour - day
2	FLOWRATE	←	21 UNIT: mL - L - m3 - mg - g - kg - ton - GAL - bbl - lb - cf - rev - no unit
↓			
↓		←	31 FUNCTION: total - flow rate
3	DISPLAY	←	
↓			
↓		←	42 BATTERY MODE: operational - shelf
		←	41 LCD UPDATE: fast - 1 sec - 3 sec - 15 sec - 30 sec - off
4	POWER MAN.	←	
↓			
↓		←	51 SIGNAL: npn - npn_lp - reed - reed_lp - pnp - pnp_lp - namur - coil_hi - coil_lo
5	FLOWMETER	←	
↓			
↓		←	65 TAGNUMBER: 0000000- 9999999
		←	64 PASSWORD: 0000 - 9999
		←	63 SERIAL NO.
		←	62 SOFTWARE VERSION
6	OTHERS	←	61 TYPE/MODEL

### 3.2.2. PROG-PROCEDURE

The PROG-procedure is applicable for programming, selecting or deleting values on SETUP-level. The procedure is executed as follows:

- 1) press PROG briefly,
- 2) enter a value or make a selection with the  $\blacktriangleright$   $\blacktriangleleft$  keys.
- 3) set the operation by pressing ENTER.

After pressing PROG, the word PROGRAM will be flashing until the PROG-procedure is completed.

To change a value, use  $\blacktriangleright$  to select the digits and  $\blacktriangleup$  to increase that value. To select a setting, both  $\blacktriangleup$  and  $\blacktriangleright$  can be used. When the new value is not valid, the increase sign  $\blacktriangleup$  or decrease-sign  $\blacktriangledown$  will be displayed while you are programming.

When data is altered but ENTER is not pressed, then the alteration can still be cancelled by waiting for 20 seconds or by pressing ENTER for three seconds: the PROG-procedure will be left automatically and the former value reinstated.

Please note that alterations will only be set after ENTER has been pressed!

### 3.2.3. SETUP

#### 3.2.3.1. TOTAL - 1

##### 11 TOTAL; MEASUREMENT UNIT - 11:

SETUP - 11 determines the measurement unit for TOTAL and accumulated Total. The following units can be selected:

L - m3 - kg - lb. - GAL - USGAL - bbl - \_ (no unit).

Alterations of the measurement unit will have consequences for operator and SETUP-level values. Please note that the K-factor has to be adapted as well.

##### 12 TOTAL; NUMBER OF DECIMALS DISPLAYED - 12:

The decimal point determines for Total and accumulated Total the number of digits following the decimal point. The following can be selected:

0000 - 111.1 - 22.22 - 3.333

##### 13 TOTAL; K-FACTOR - 13:

With the K-factor, the flow meter pulse signals are converted to a quantity. The K-factor is determined on the basis of the measurement unit and the number of pulses generated per unit by the flow meter. Enter the number of pulses generated by the flow meter per selected measurement unit (per cubic meter e.g.). The more accurate the K-factor, the more accurate the functioning of the system will be.

Example 1: Calculating the K-factor.

*Let us assume that the flow meter generates 2.4813 pulses per liter and the selected unit is "cubic meters / m3". A cubic meter consists of 1000 parts of one liter, which implies 2,481.3 pulses per m3. So, the K-factor is 2,481.3. Enter for SETUP - 13: "2481300" and for SETUP - 14 - decimals K-factor "3".*

Example 2: Calculating the K-factor.

*Let us assume that the flow meter generates 6.5231 pulses per gallon and the selected measurement unit is Gallons. So, the K-Factor is 6.5231. Enter for SETUP - 13: "6523100" and for SETUP - 14 decimals K-factor "6".*

##### 14 TOTAL; NUMBER OF DECIMALS FOR K-FACTOR TOTAL - 14:

This function determines the number of decimals for the K-factor (see 13). The following can be selected:

0 - 1 - 2 - 3 - 4 - 5 - 6

Please note that this function influences the accuracy of the K-factor indirectly. This setting has NO influence on the displayed number of digits for Total (SETUP 12)!

**3.2.3.2. FLOWRATE - 2**

The settings for Total and flow rate are entirely separated. In this way, different measurement units can be used like cubic meters for Total and liters for flow rate. Please notice that all these settings influence the analog output as well.

**21 FLOW RATE ; MEASUREMENT UNIT - 21:**

SETUP - 21 determines the measurement unit for flow rate.

The following units can be selected:

mL - L - m3 - mg - gr - kg - ton - GAL - bbl - lb. - cf - rnd (round for RPM) \_ (no unit).

Alterations of the measurement unit will have consequences for operator and SETUP-level values. Please note that the K-factor has to be adapted as well.

**22 FLOW RATE ; TIME UNIT - 22:**

The actual flow rate can be calculated per second (SEC), minute (MIN), hour (HR) and day (DAY).

**23 FLOW RATE ; NUMBER OF DECIMALS DISPLAYED- 23:**

The decimal point determines for flow rate the number of digits following the decimal point. The following can be selected:

00000 - 1111.1

**24 FLOW RATE ; K-FACTOR - 24:**

With the K-factor, the pulse signals of the flowmeter are converted to a quantity. The K-factor is determined on the basis of the measurement unit and the number of pulses generated per unit by the flowmeter. Enter here the number of pulses generated by the flow meter per selected measurement unit (per Liter e.g.). The more accurate the K-factor, the more accurate the functioning of the system will be. For examples see SETUP 13.

**25 FLOW RATE ; NUMBER OF DECIMALS FOR K-FACTOR - 25:**

This function determines the number of decimals for the K-factor (see 24).

The following can be selected:

0 - 1 - 2 - 3 - 4 - 5 - 6

Please note that this SETUP - influences the accuracy of the K-factor indirectly.

This setting has NO influence on the displayed number of digits for "flow rate" (SETUP 23)!

**26 FLOW RATE ; CALCULATION - 26:**

The flow rate is calculated by measuring the time between pulses. As several types of flow meters have an unequal pulse-train, it is advised to calculate the flow rate over several pulses, for example 10 pulses; the maximum value is 255 pulses. Please understand that the calculation time for very low frequencies (0.1-5Hz) is influenced by this setting as well; so do not program too many pulses! When the frequency is above 3kHz. During normal conditions, it is advised to calculate over 50 or more pulses.

**27 FLOW RATE ; CUT-OFF TIME - 27:**

With this setting, you determine when a flow rate is zero; when during this time less than XX-pulses (see setting 26) is generated, the flow rate will be displayed as zero.

**3.2.3.3. DISPLAY - 3**

**31 DISPLAY; FUNCTION - 31**

The large 17mm digits can be set to display Total or flow rate. When Total is selected, both Total and flow rate are displayed simultaneously. When flow rate is selected, Total will be displayed after pressing select. .

### 3.2.3.4. POWER MANAGEMENT - 4

As the F012-P is normally battery powered, the user will have the concern of reliable measurement over a long period of time. The F012-P has several smart power management functions to extend the battery lifetime significantly. Two of these functions can be set:

#### 41 POWER MANAGEMENT; LCD NEW - 41:

The calculation of the display -information influences the power consumption significantly. When the application does not require a fast display update, we advise you to select a slow refresh-rate. Please understand that NO information will be lost; every pulse will be counted and the output-signals are not influenced.

The following can be selected:

Fast - 1 sec - 3 sec - 15 sec - 30 sec - off.

Example: battery lifetime with a coil pick-up, 1KHz. pulses and FAST update: about 2 years.  
Battery lifetime with a coil pick-up, 1KHz. pulses and 1 sec update: about 7 years.

Please note that - after the operator has pressed a button - the display refresh-rate will always be FAST during 30 seconds. When "OFF" is selected, the display will be switched-off after 30 seconds and will be switched-on as soon as a button has been pressed.

#### 42 POWER MANAGEMENT; BATTERY-MODE - 42:

The unit has two modes: operational or shelf. When shelf is selected, you can store the unit for several years; it will not count pulses, the display is switched off but all settings are stored. In this mode, power consumption is extremely low.

Normally, the unit will be operational.

### 3.2.3.5. FLOWMETER - 5

#### 51 FLOW METER; SIGNAL - 51:

The F012-P is able to handle several types of signals. The type of flow meter pickup / signal is selected in software with SETUP 51.

TYPE OF SIGNAL	EXPLANATION	RESISTANCE	POWER CONSUMPTION	FREQ. / mV	REMARK
NPN	Standard NPN input	100K pull-up	Relative high	16 KHz.	(open collector)
NPN - LP	NPN with low pass filter	100K pull-up	Relative high	2.2 KHz.	(open collector) less sensitive
REED	Reed-switch input	1M pull-up	low	2.2 KHz.	
REED - LP	Reed-switch + low pass filter	1M pull-up	low	225 Hz.	Less sensitive
PNP	Standard PNP input	100K pull-down	Relative high	6.3 KHz.	
PNP - LP	PNP input with low pass filter	100K pull-down	Relative high	700 Hz.	Less sensitive
NAMUR	Standard namur input	1K pull-down	High	12 KHz.	External power required
COIL HI	High sensitive coil input	-	Very low	25mV p.t.p.	Sensitive for disturbance!
COIL LO	Low sensitive coil input	-	Very low	90mV p.t.p.	Normal sensitivity

**3.2.3.6. OTHERS - 6**

**61 OTHERS; TYPE OF MODEL - 61:**

For support and maintenance it is important to have information about the characteristics of the rate/totaliser. Your supplier will ask for this information in case of a serious breakdown or a desired extension of the system.

**62 OTHERS; VERSION SOFTWARE - 62:**

For support and maintenance it is important to have information about the characteristics of the rate/totaliser. Your supplier will ask for this information in case of a serious breakdown or a desired extension of the system.

**63 OTHERS; SERIAL NUMBER - 63:**

For support and maintenance it is important to have information about the characteristics of the rate/totaliser. Your supplier will ask for this information in case of a serious breakdown or a desired extension of the system.

**64 OTHERS; PASSWORD - 64:**

All SETUP-values can be password protected. This protection is disabled with value 0000 (zero). Up to and including 4 digits can be programmed, e.g. 1234.

**65 OTHERS; TAGNUMBER - 65:**

For identification of the unit and communication purposes, a unique tag number of maximum 7 digits can be entered.

4. INSTALLATION

4.1. GENERAL DIRECTIONS

- ◆ Authorized technicians must carry out installation, use, maintenance and de-mounting of this equipment only.
- ◆ Take good notice of the "Safety rules and precautionary measures" in the front of this manual.
- ◆ For Intrinsically Safe applications: read chapter 5.

4.2. INSTALLATION / SURROUNDING CONDITIONS

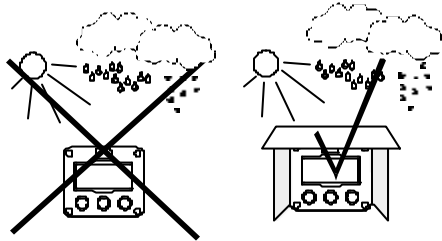

Take the valid IP classification of the casing into account (see manufactures plate). NEVER expose even the IP65 casing to strongly varying (weather) conditions. When panel-mounted, the unit is IP65! When used in very cold surroundings or heavy varying temperatures, take the necessary precautions against moisture by placing a dry sachet of silica gel e.g. before closing in the casing.

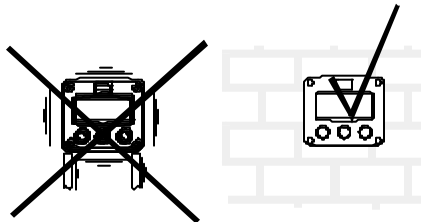

Do mount the rate/totaliser on solid ground surface to avoid vibrations.

4.3. DIMENSIONS

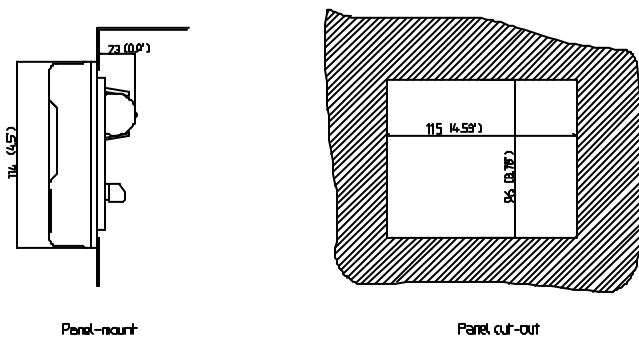

Fig. 6: Dimensions ABS panel mount casing / panel cut-out (IP65).

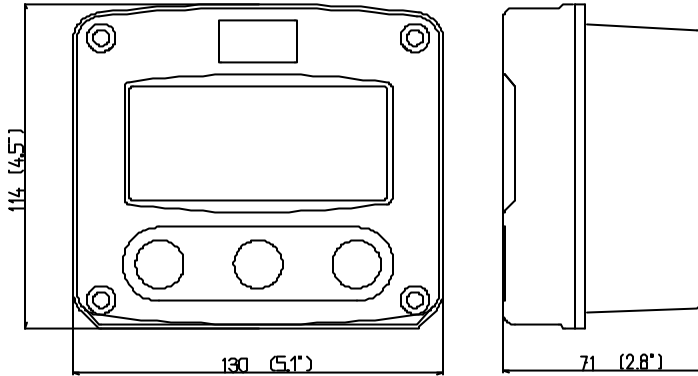

Fig. 7: Dimensions ABS wall-mount casing.

#### 4.4. INSTALLING THE HARDWARE

##### 4.4.1. INTRODUCTION

- ◆ *This unit must be installed in accordance with the EMC guidelines (Electro Magnetic Compatibility).*
- ◆ *Electro static discharge does inflict irreparable damage to electronics! The electrician has to discharge himself by touching a well-grounded object before opening the casing.*
- ◆ *For Intrinsically Safe applications: read chapter 5.*

##### FOR INSTALLATION, PAY EMPHATIC ATTENTION TO:

- ◆ Separated cable glands with effective IP67 seals for all wires.
- ◆ Not used cable entries: do place closed IP67 plugs.
- ◆ A reliable grounding of the several components, electronics and - if be applicable - metal casing.
- ◆ An effective screened cable for signal wiring and grounding of the screening in terminal 3 (GND).

##### 4.4.2. VOLTAGE SUPPLY FLOWMETER PICK-UP

*For Intrinsically Safe applications: read chapter 5.*

##### Externally powered applications 8-30 V DC:

When the F012-P is externally powered, the sensor can be powered with the same voltage only by using the same terminal (4). If the unit is battery powered as well, the out-going voltage of 3.2V DC is blocked automatically as soon as you connect the external power-supply.

##### Battery powered and loop powered applications:

A supply voltage of 3.2 Volt DC is available for the signal output of the flow meter. ***This voltage MAY NOT be used to power the flow meters electronics, converters etc.*** as it is not a power output! All energy used by the flow meters pick-up influences the battery lifetime directly; it is strongly advised to use a "zero power" pickup as a coil or reed-switch. It is possible to use a NPN or PNP output signal, but the battery lifetime will be reduced.

**NAMUR**

For a NAMUR pick-up, an external power supply of 8.2-24VAC/DC is required. The voltage supply to the flow meter should be according DIN19 234 (8.2VDC) when NAMUR-input is selected. Please note that the optional power-module can be used!

**4.4.3. TERMINAL CONNECTORS**

For *Intrinsically Safe* applications: read chapter 5.

Following terminal connectors are available:

FLOWMETER INPUT			DC INPUT : OUTPUT	
1	2	3	4	5
COIL	PULSE	⊥	+↕	P.L

Fig.: 8 Overview terminal connectors.

**REMARKS TERMINAL CONNECTORS:**

**Terminal 1-3; Flow meter input**

Two basic types of flow meter signals can be connected to the F012-P: pulse (terminal 2) or coil (terminal 1). The screen of the signal wire must be connected to terminal 03 (GND). The voltage supply (3.2VDC) to the flow meter should be connected to terminal 4. Please read par. 4.4.2. for power supply flow meter. The maximum input frequency is approximately 10 KHz (depending on the type of signal) **For Intrinsically safe applications: please read chapter 5.**

**Coil-signal:**

The F012-P is suitable for flow meters, which have a coil output. The sensitivity of the input can be selected with SETUP - 51. Two selections can be made: COIL LO: sensitivity from about 120mV peek to peek (p.t.p.) or COIL HI: sensitivity from about 20mV peek to peek.

**For Intrinsically safe applications: please read chapter 5.**

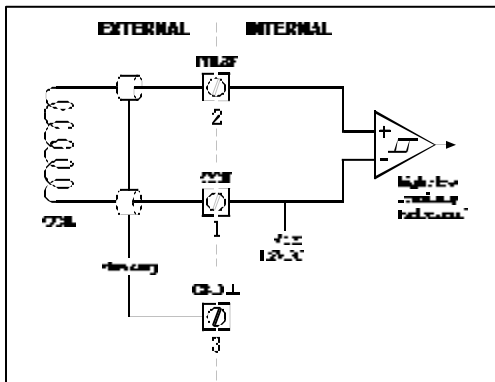

**Pulse-signal NPN/PNP:**

The F012-P is suitable for flow meters, which have a pulse output that is equal or almost equal to the supply voltage (3.2VDC). For a reliable detection, the pulse amplitude has to cross 1.2VDC once per cycle. Transducers which generate a higher amplitude than 3.2VDC can be used but the detection level is still 1.2VDC. Maximum voltage input is rated for pulse amplitudes of 24VDC.

**For Intrinsically safe applications: please read chapter 5.**

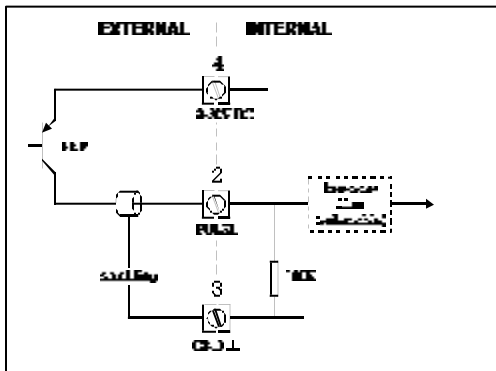
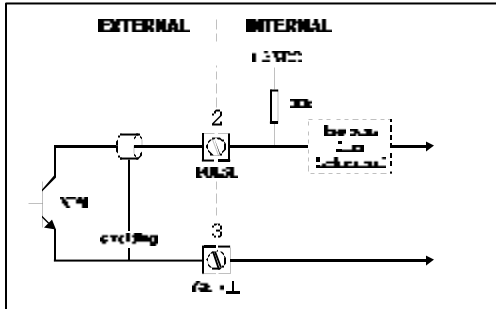

**Reed-switch:**

The F012-P is suitable for flow meters, which have a reed-switch. To avoid pulse bounce from the reed-switch, it is advised to select REED LP - low-pass filter (setting 51).

**For Intrinsically safe applications: please read chapter 5.**

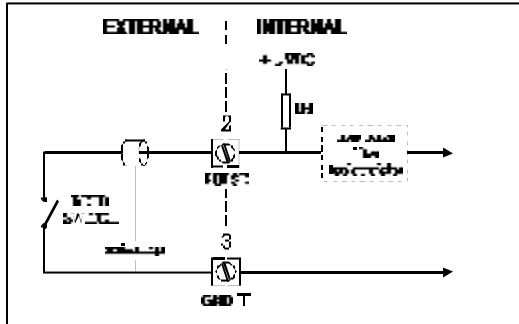

**NAMUR-signal:**

The signal input is according DIN19 234. Please notice that an external power supply is required. Maximum voltage input is 10VDC for NAMUR-type input.

**For Intrinsically safe applications: please read chapter 5.**

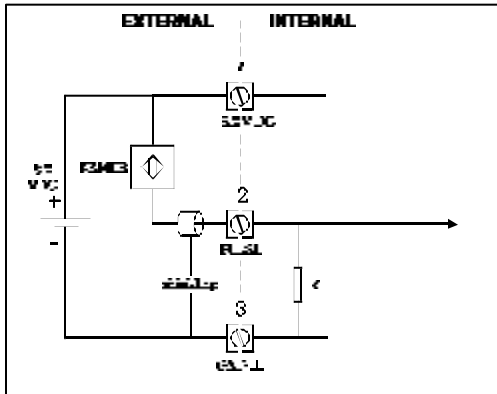

**Terminal 4 and 5; external power supply 8-30V DC:**

Connect an external power-supply of maximum 30V DC to these terminals. Connect the "-" to terminal 5 and the "+" to terminal 4. The out-going voltage from the battery (option) is blocked automatically as soon as a higher voltage as 3.2 V DC is connected: it won't damage the battery.

**5. INTRINSIC SAFETY CONNECTIONS**

The F012-P can be installed in hazardous area when option XI for intrinsically safe has been supplied. In most applications, the classification for the F012-P-XI is EEx ia IIB T4 where a maximum of two barriers can be connected to the unit. However, the F012-P-XI can be used in gas group C applications according EEx ia IIC T4 when no external barriers are connected to the unit. Please study following pages with wiring diagrams per signal type for coil, NPN, PNP, reed-switch and Namur sensors.

**When installing the F012-P-XI in hazardous areas, the wiring and installation must comply with appropriate installation standards.**

**COIL INPUT CIRCUIT: TERMINALS 1 (COIL), 2 (SIGNAL) AND 3 (GND):**

In type of explosion protection intrinsic safety EEx ia IIB T4, only for connection to a certified intrinsically safe circuit, with following maximum values:

- Ui = 30V DC
- Ii = 100mA
- Pi = 0.75W

the effective internal capacitance and inductance are negligibly small.

**COIL INPUT CIRCUIT: TERMINALS 1 (COIL), 2 (SIGNAL) AND 3 (GND):**

In type of explosion protection intrinsic safety EEx ia IIC T4 or EExia IIB T4, only for connection to a certified intrinsically safe circuit, with following maximum values:

- Uo = 5.1V
- Io = 5.2mA
- Po = 27mW

maximum allowed external capacitance Co and maximum allowed external inductance Lo depending on gas group, in accordance with following table:

	IIB	IIC
Lo <=	1H	1H
Co <=	1000uF	88uF

**NAMUR INPUT CIRCUIT: TERMINALS 2 (SIGNAL) AND 3 (GND):**

In type of explosion protection intrinsic safety EEx ia IIB T4, only for connection to a certified intrinsically safe circuit, with following maximum values:

- Ui = 30V DC
- Ii = 100mA
- Pi = 0.75W

the effective internal capacitance and inductance are negligibly small.

**PNP INPUT CIRCUIT: TERMINALS 2 (SIGNAL) AND 3 (GND):**

In type of explosion protection intrinsic safety EEx ia IIB T4, only for connection to a certified intrinsically safe circuit, with following maximum values:

- Ui = 30V DC
- Ii = 100mA
- Pi = 0.75W

the effective internal capacitance and inductance are negligibly small.

**PNP INPUT CIRCUIT: TERMINALS 2 (SIGNAL) AND 4 (SUPPLY):**

In type of explosion protection intrinsic safety EEx ia IIC T4 or EEx ia IIB T4, only for connection to a certified intrinsically safe circuit, with following maximum values:

- Uo = 5.1V
- Io = 5.2mA
- Po = 27mW

maximum allowed external capacitance Co and maximum allowed external inductance Lo depending on gas group, in accordance with following table:

	IIB	IIC
Lo <=	1H	1H
Co <=	1000uF	88uF



**NPN OR REED-SWITCH INPUT CIRCUIT: TERMINALS 2 (SIGNAL) AND 3 (GND):**

In type of explosion protection intrinsic safety EEx ia IIB T4, only for connection to a certified intrinsically safe circuit, with following maximum values:

$$U_i = 30V \text{ DC}$$

$$I_i = 100mA$$

$$P_i = 0.75W$$

the effective internal capacitance and inductance are negligibly small.

**NPN OR REED-SWITCH INPUT CIRCUIT: TERMINALS 2 (SIGNAL) AND 3 (GND): :**

In type of explosion protection intrinsic safety EEx ia IIC T4 or EEx ia IIB T4, only for connection to a certified intrinsically safe circuit, with following maximum values:

$$U_o = 5.1V$$

$$I_o = 5.2mA$$

$$P_o = 27mW$$

maximum allowed external capacitance  $C_o$  and maximum allowed external inductance  $L_o$  depending on gas group, in accordance with following table:

	IIB	IIC
$L_o \leq$	1H	1H
$C_o \leq$	1000uF	88uF

**EXTERNAL POWER SUPPLY: TERMINALS 4 (SUPPLY), 3 (GND):**

In type of explosion protection intrinsic safety EEx ia IIB T4, only for connection to a certified intrinsically safe circuit, with following maximum values:

$$U_i = 30V \text{ DC}$$

$$I_i = 100mA$$

$$P_i = 0.75W$$

the effective internal capacitance and inductance are negligibly small.

**BATTERY POWERED UNITS:**

In accordance with the certificate, only the I.S. certified battery type FW-LiBAT-001 has to be used in case of replacement.

**CERTIFICATE F012-P-XI:**

Certificate of conformity for the F012-P-XI: **Ex-KEMA No. Ex-00.E.1109 X**



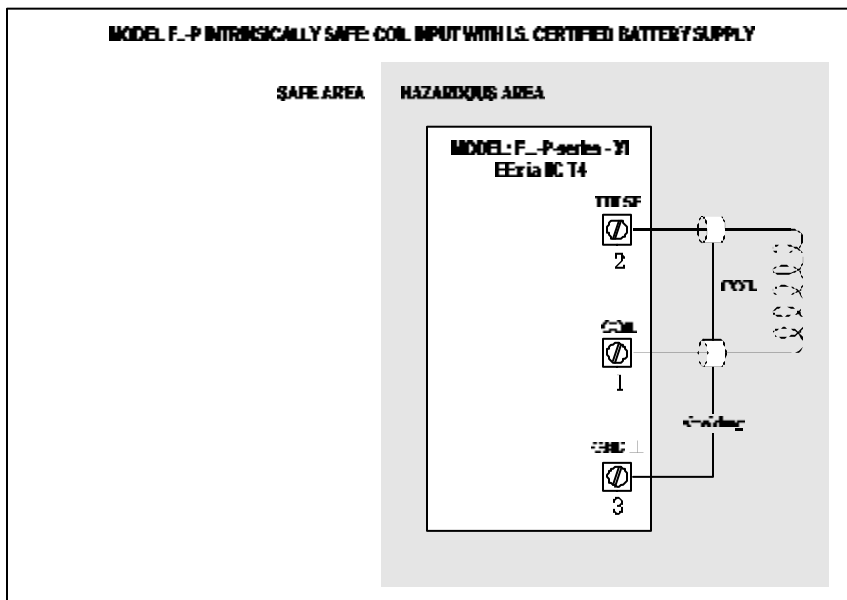
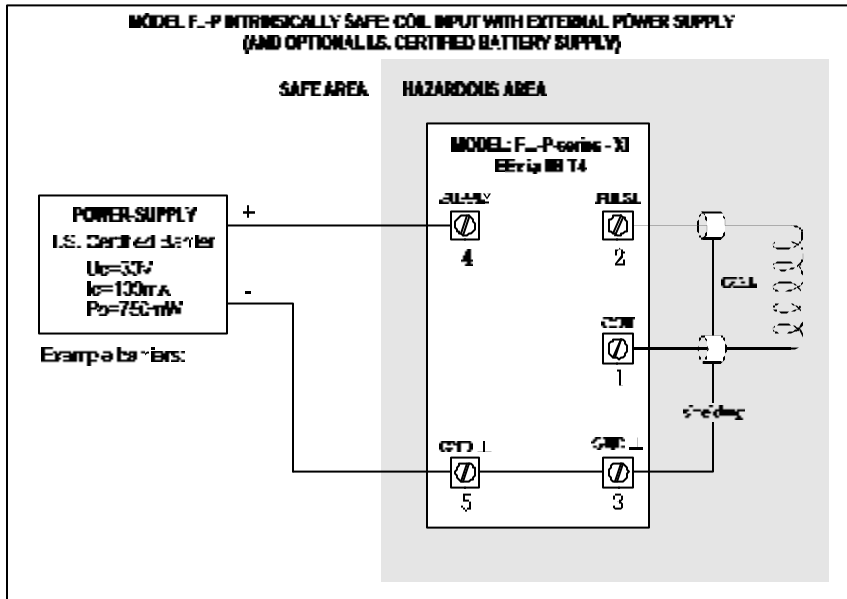

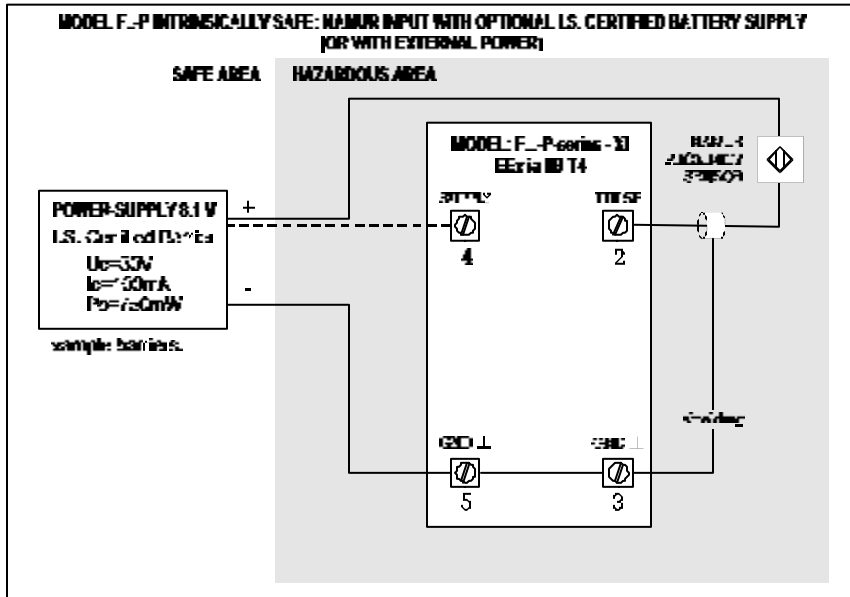
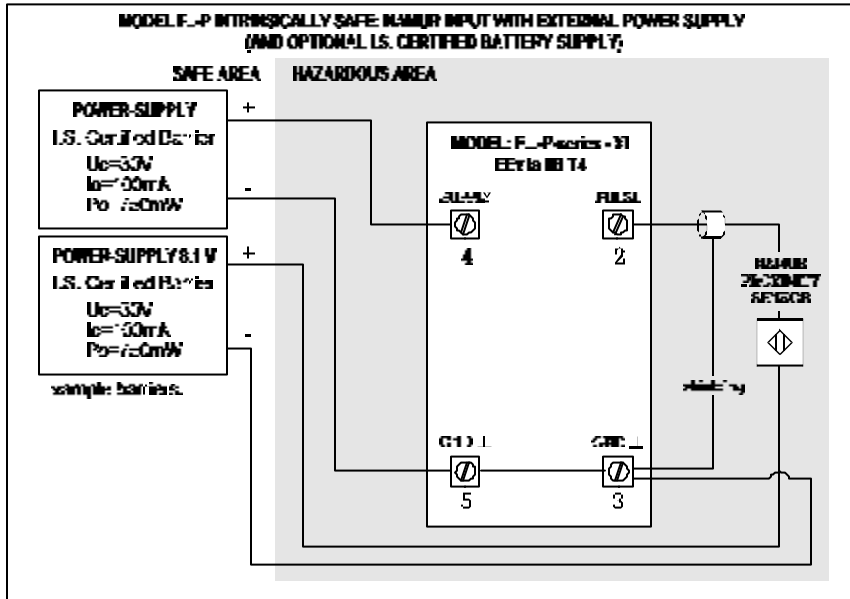

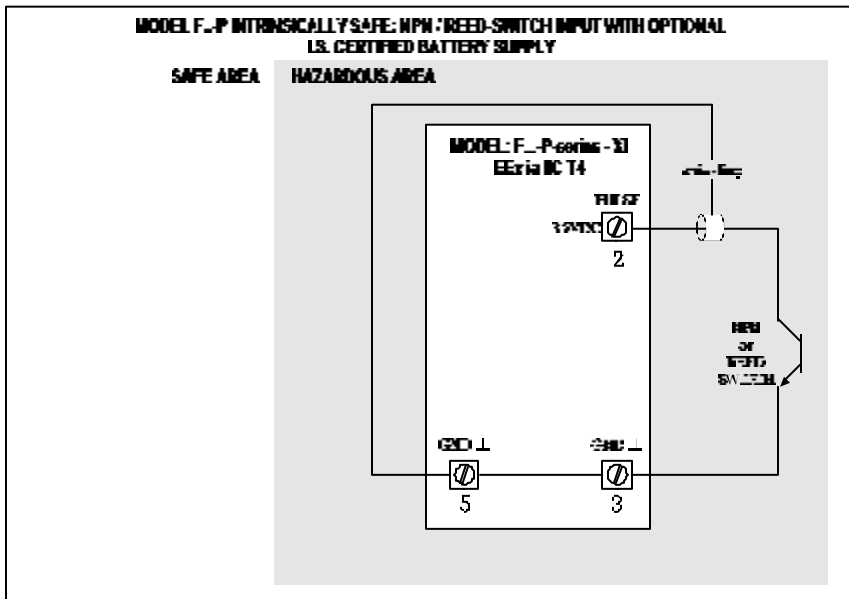
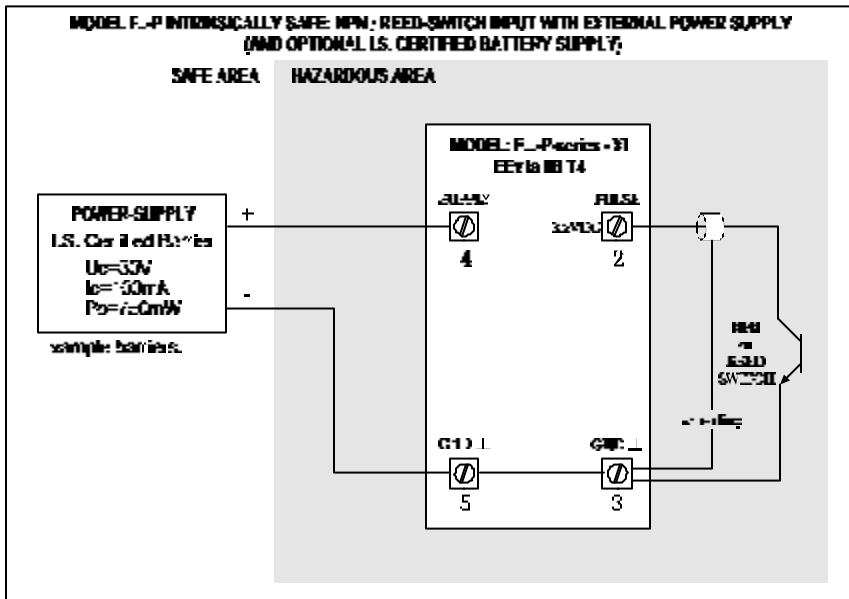

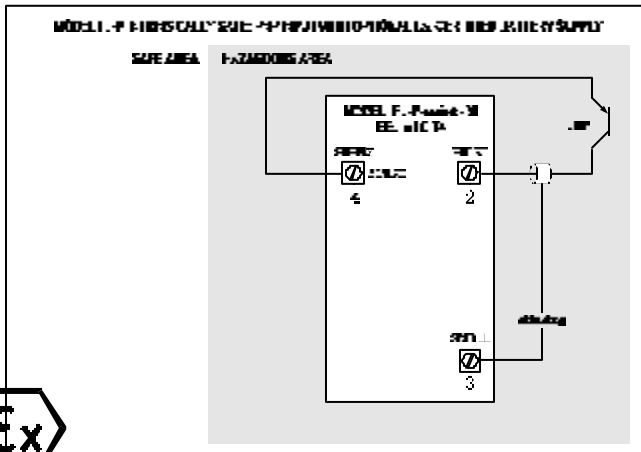
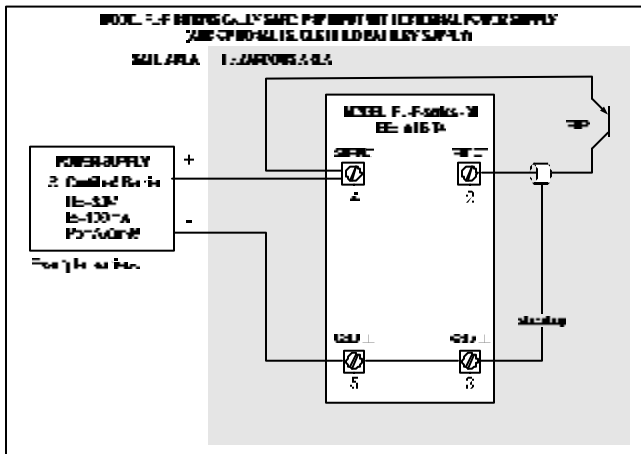
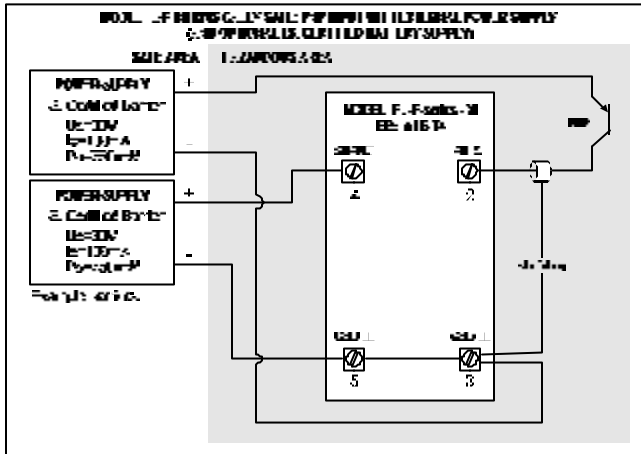

## 6. MAINTENANCE

### 6.1. GENERAL DIRECTIONS

- ◆ *Authorized technicians must carry out installation, use, maintenance and de-mounting of this equipment only.*
- ◆ *Take good notice of the "Safety rules and precautionary measures" in the front of this manual.*

The rate/totaliser does not require special maintenance unless it is used in low-temperature applications and/or surroundings with high humidity (above 90% annual mean). It is customer's responsibility to take all precautions to dehumidify the internal atmosphere of the F012-P in such a way that no condensation will take place, for example by placing dry silica gel in the casing just before closing it. Furthermore, is required to replace or dry the silica gel time to time as advised by the silica gel supplier.

#### **Battery life-time:**

It is influenced by several issues such as:

- Display update: see setting 41.
- low temperatures; the available power will be less due to battery chemistry.

It is advised to disable unused functions.

#### **Check periodic:**

- ◆ The condition of the casing, cable glands and front panel.
- ◆ The wiring of the several components on reliability and aging symptoms.
- ◆ The process accuracy. As a result of wear and tear, re-calibration of the flow meter might be necessary. Do adapt the actual K-factors.
- ◆ The indication for low-battery.
- ◆ Clean the casing with soap-water; don't use any aggressive solvents as these might damage the ABS or coating.

**APPENDIX A: TECHNICAL SPECIFICATION F012-P****GENERAL**

Display:	High intensity reflective alphanumeric LCD, UV-resistant.
Digits:	Seven 17mm (0.67") and eleven 8mm (0.31"). Various symbols and measuring units.
Refresh rate:	Selectable via menu: 8 times/sec - 30 sec's.
Case:	ABS - IP65 / NEMA 4.
Mounting:	Standard panel-mount case.
Dimensions:	130 x 114 x 50mm (5.1" x 4.5" x 1.97") - LxHxD.
Panel cut-out:	115 x 96mm (4.53" x 3.78") LxH.
Window:	Polycarbonate window.
Sealing:	EPDM and PE.
Control keys:	Three industrial micro-switch keys. UV-resistant polyester keypad.
Option HD:	ABS IP65 / NEMA 4 wall-mount casing. Dimensions: 130 x 114 x 71mm (5.1" x 4.5" x 2.8") - LxHxD.
Option HA:	Aluminium IP67 / NEMA 4 wall-mount, sensor head-mount. Dimensions: 130 x 114 x 58mm (5.1" x 4.5" x 2.3") - LxHxD.
Operating temperature:	-30°C to +80°C (-22°F to +178°F).
Power requirements:	8-30V DC supply can be connected to power the unit.
Option PA:	Internal Lithium battery 3.2V DC: average lifetime seven years dependent upon settings and sensor type.
Sensor excitation:	same voltage as offered to power the unit.
Terminal connections:	Removable plug strip. Wire max. 1.5mm2.
Data protection:	EEPROM backup of all setting. Backup total and accumulated total every minute.
Hazardous area:	(optional) Cenelec approval ref: EEx ia IIB/IIC T4. CSA certification is pending. Maximum ambient 70°C (158°F). Option XI.
Environment CE:	EMC compliant ref: EN50081 and EN50082.
Pulse inputs:	Type P: Coil/sine wave (minimum 20mVpp or 80mVpp - sensitivity selectable), NPN/PNP, open collector, reed-switch, Namur.
Frequency:	Minimum 0 Hz - maximum 10 KHz for total and flow rate. Max frequency depends on signal type and internal low-pass filter. Reed switch with low-pass filter = max. 200 Hz.
Low-pass filter:	Available for all pulse signals.
Selection main function:	Total or flow rate will be displayed with 17mm digits.

**OPERATOR FUNCTIONS**

General:	The Operator has three functions available: <ul style="list-style-type: none"> <li>- TOTAL and flow rate are displayed.</li> <li>- TOTAL can be reset by pressing CLEAR-key twice.</li> <li>- After pressing SELECT, accumulated TOTAL will be displayed.</li> </ul>
TOTAL:	17mm character-size - 7 digits. Measuring units: L, m3, GAL, USGAL, KG, lb, bbl, no unit. K-factor: 7 positions 0.000010 - 9,999,999. Number of decimals: max. three. TOTAL is reset able.
Accumulated total:	8mm character-size - 11 digits. Acc. total is not reset able. Uses same K-factor, unit and decimals as TOTAL.
FLOWRATE:	8mm character-size or 17mm character-size - 5 digits. Settings independent of TOTAL. Measuring units: mL, L, m3, Gallons, KG, ton, lb, bl, cf, rnd, no unit. Time units: second, minute, hour, day. K-factor: 7 positions 0.000010 - 9,999,999. Number of decimals: max. one.

**APPENDIX B: PROBLEM SOLVING**

In this appendix, several problems are included that can occur when the rate/totaliser is going to be installed or while it is in operation.

**Flow meter does not generate pulses:**

Check:

- Flow meter, wiring and connection of terminal connectors (par. 4.4.4.),

**Flow meter does generate "too many pulses":**

Check:

- Settings for Total and Flow rate: SETUP 11-14 and 21-27,
- Proper grounding of the F012-P - par. 4.4.4.
- Use screened wire for flow meter signals and connect screen to terminal 9.
- Check the linearization function.

**Flow rate displays "0 / zero" while there is flow (total is counting):**

Check:

- SETUP 22 / 25: are the K-factor and time unit correct?
- SETUP 26 / 27: The unit has to count the number of pulses according to setup 26 within the time according to setup 27. Make sure that 27 is set like 10.0 seconds e.g. : the result is that the unit has at least 10 seconds time to measure the number of pulses according to setup 26.

**The password is unknown:**

If the password is not 1234, there is only one possibility left: call your supplier.

**ALARM**

When the alarm flag starts to blink an internal alarm condition has occurred. Press the "select button" several times to display the 5-digit error code. The codes are:

- 0001: irrecoverable display -data error: data on the display might be corrupted.
- 0002: irrecoverable data-storage error: the programming cycle might have gone wrong: check programmed values.
- 0003: error 1 and error 2 occurred simultaneously

The alarm condition will most certainly be handled internally and if all mentioned values still appear right, no intervention of the operator is needed. In case the alarm occurs more often or stays active for a longer time, please contact your supplier.

## INDEX:

accumulated Total	4	maintenance	22
actual settings	28	model	10
Battery powered	12; 17	NAMUR signal	12; 15; 16
<b>CLEAR</b>	3	Notes	26
Clear Total	4	operational mode	9
Coil-signal	13; 16	Operator level	4
Configuration	5	password	10; 24
Dimensions	11	Power management	9
display update	9	Problem solving	24
flowmeter		<b>PROG / ENTER</b>	3
signal	9	PROG-procedure	7
Flowmeter input	13; 16	Pulse-signal NPN/PNP	14; 16; 17
flowrate		rate/Total	4
calculation	8	Reed-switch:	15; 17
cut-off time	8	<b>SELECT</b>	3
decimals	8	serial number	10
decimals k-factor	8	SETUP-level	5
display 17mm digits	8	shelf -mode	9
k-factor	8	subfunction	5
measuring unit	8	tagnumber	10
time unit	8	Technical specification	23
Installation	11	terminal connectors	13
Intrinsic safety	16	total	
IP classification	11	decimals	7
keys	3	decimals kfactor	7
loop powered	15	k-factor	7
low-battery	4	measuring unit	7
Low-battery alarm	4	version software	10
main-function	5		





LIST OF ACTUAL SETTINGS F012-P

SETTING:	STANDARD	DATE:	DATE:
----------	----------	-------	-------

**1 - TOTAL:**

11 unit	L		
12 decimals	0000000		
13 K-factor	0000001		
14 decimals K-factor	0		

**2 - FLOWRATE:**

21 unit	L		
22 time unit	/min		
23 decimals	0000000		
24 K-factor	0000001		
25 decimals K-factor	0		
26 calculation / pulses	10		
27 cut-off time	30.0 sec.		

**3 - DISPLAY**

31 function	total		
-------------	-------	--	--

**4 - POWER MAN.**

41 LCD-new	1 sec.		
42 mode	operational		

**5 - FLOWMETER**

51 signal type	coil-lo		
----------------	---------	--	--

**6 - OTHERS**

64 password	0000		
65 tag number	0000000		